

Lumiglas Light/Sight Glass Fitting ESKS and SKS

- **Hinged sight glass frame with or without luminaire**

- **Application:**

ESKS integral light/sight glass fittings have a quick release closure, so that they are a combination of charge/access port and light/sight glass. The integrated luminaire illuminates the internal of boilers, tanks, bunkers, silos, mixers and other vessels in all non Ex hazardous areas.

SKS type sight glass ports are of the same design, except they have no luminaire. Both types are suitable for food processing. Usually these fittings come with a weld flange, but for flat vessel walls they can also be installed with a bolt-on flange.

- **Safety precaution:**

The fitting must never be opened **before the pressure inside the vessel is reduced to zero!**

- **Protection:**

When correctly fitted, dust and waterjet proof to IP 65, EN 60 529 / DIN VDE 0470 T1

- **Ambient condition operating range:**

The fitting is vacuum proof

and resistant to: 0.5 bar type SKS/ESKS 225

1.0 bar type SKS/ESKS 150

max. vessel temp.: 150°C with soda lime glass

200°C with borosilicate glass

ambient temp.: max. 80°C at the cable gland.

When ambient temp. > 40°C heat resistant cable e.g. Sinothem 110 H05GG-F 3G 1.5 mm² must be used

- **Electrical data:**

power supply 24 V or 120 V, halogen lamp 50 or 100 W, 2-pin socket GY 6.35

- **Transformers** can be supplied as extra item

- **Combination** with sight glass wiper SW I is possible

- **Mechanical fitting:**

Caution: Do not look into light – danger of impaired eyesight!
The fitting comes ready assembled. Before welding, the sight glass frame and the hinge assembly should be removed from the base flange. Check desired position i.e. direction of swing. The lug and hinged assembly holes are not identically spread. The weld flange must be welded into the vessel wall free of distortion; bolt-on flanges require an entirely flat vessel wall.

- 1 Lumistar luminaire (only with ESKS)
- 2 luminaire frame with sight glass
- 3 weld flange (resp. bolt-on flange with drilled holes)
- 4 closure knob
- 5 closure lug
- 6 hinged assembly
- 7 astening ring (only with SKS, instead of luminaire)

- **Lamp change:**

Since the fitting must be opened for lamp change, reduce pressure in the vessel to zero, and put vessel out of operation. Check vessel for pressure and temperature before opening a sight glass fitting!

CE

3755.169 e



Lumiglas light sight glass fitting ESKS

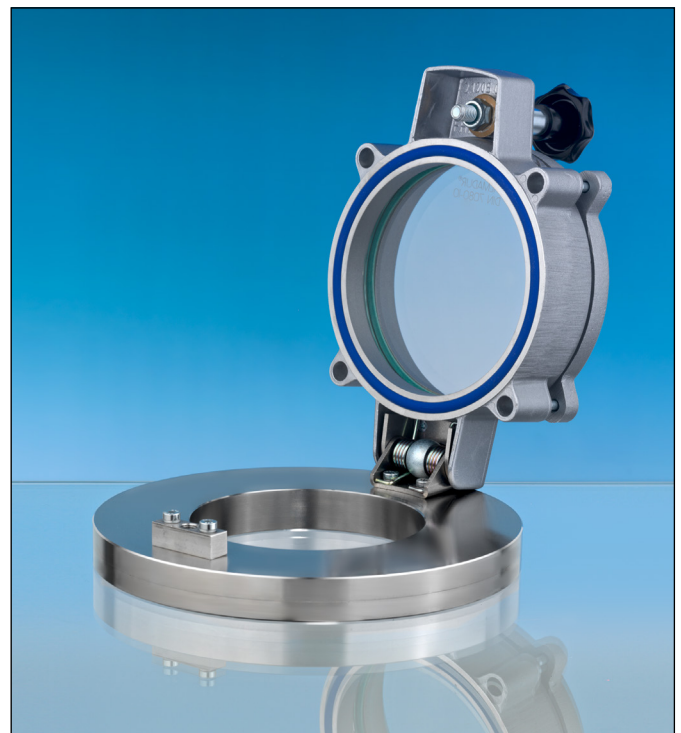

Lumiglas sight glass fitting SKS

• **Dimensions and electrical data of Lumiglas light/sight glass fittings ESKS and SKS:**

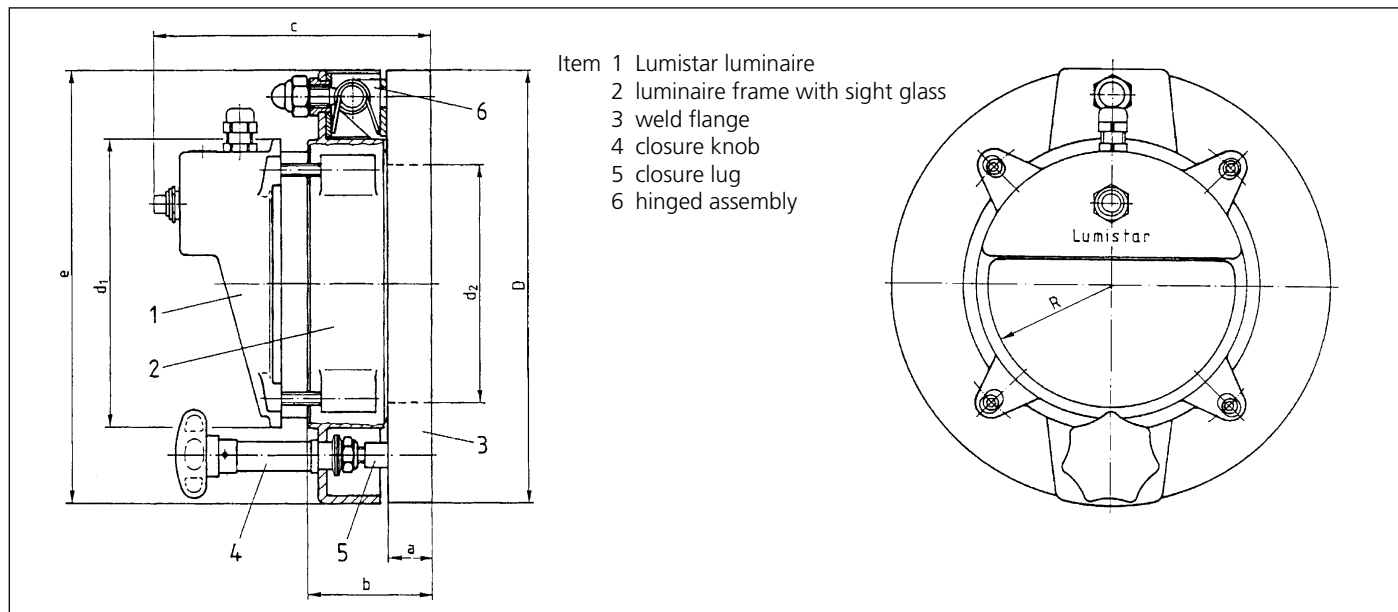

• **Parts, construction and materials:**

- Luminaire body: corrosion resistant die cast aluminium, painted RAL 9007
- Weld flange: steel S235JR+N (RSt 37-2) oder stainless steel, e.g. 1.4541 or 1.4571
- Sight glass disc: toughened (tempered) soda-lime glass or borosilicate
- Seals: silicon rubber
- Lock: galvanized or painted steel; star handle: plastic

• **Ordering information:** e. g. Lumiglas light/sight glass fitting type 150, 24 V, 100 W, weld flange 1.4571, max. temp. 200°C

• **Special design:** Upon request all metal parts getting in contact with the product can be realised in stainless steel (304L).

Type		ESKS 150	SKS 150	ESKS 225	SKS 225
Dimensions	a	25	25	25	25
	b	71	71	80	80
	c	185.5	90	167	100
	d1	165	165	235	235
	e	250	250	335	335
	d2	136	136	205	205
	D	250	250	335	335
	R	70	70	104	104
Voltage		24 V	no luminaire	24 V	no luminaire
Power		max. 100 W	just sight glass	max. 100 W	just sight glass

• **Lamp change:**

Before opening the port, vessel operation must be stopped and vessel must not be under pressure or temperature:

- Switch off and disconnect luminaire
- Unscrew the fastening screws from the luminaire housing and remove luminaire 1 from frame 2
- Remove reflector and withdraw defective lamp

- Replace halogen lamp with lamp of same type and size, use protective paper to ensure bare fingers do not touch the glass, insert 2-pin socket hole and push in gently but firmly
- Refit reflector, fasten luminaire 1 on frame 2 with fastening screw
- Switch power to 'ON' and check for proper function